



EST 200 : DESIGN AND ENGINEERING MODULE 3

Manu Prasad

Asst. Professor, Dept. of ECE

AWH Engineering College, Kozhikode 08

Email : manuprasad@awhengg.org





SYLLABUS

- ✓ Design Communication (Languages of Engineering Design):-
- ✓ Communicating Designs Graphically,
- ✓ Communicating Designs Orally and in Writing.
- ✓ Mathematical Modeling In Design, Prototyping and Proofing the Design.

ENGINEERING SKETCHES

- Drawing is very important in design because a lot of information is created and transmitted in the drawing process.
- Design drawings include sketches, freehand drawings, and
- computer-aided design and drafting (CADD) models that extend from simple wire-frame drawings through elaborate solid models

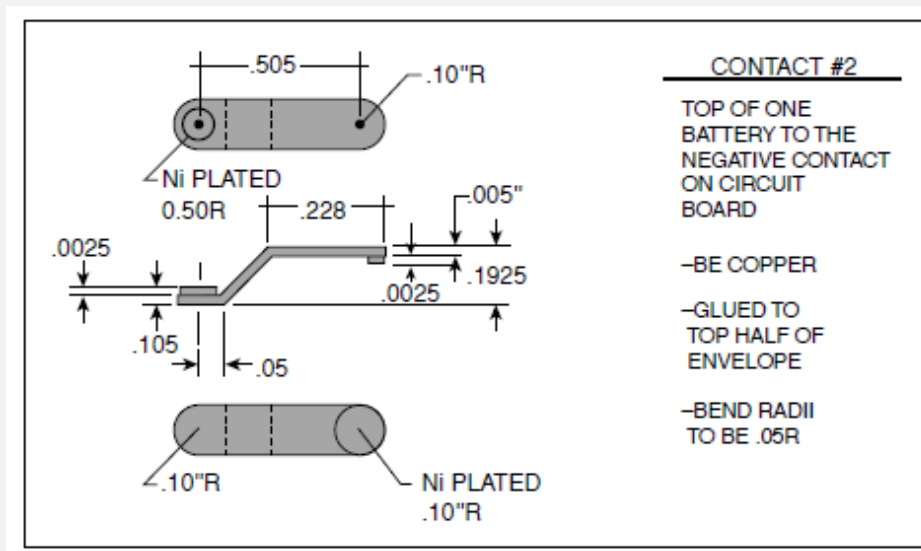



ENGINEERING SKETCHES

- In brief, graphic images are used to communicate with other designers, the client, and the manufacturing organization. Sketches and drawings:
 - serve as a launching pad for a brand-new design;
 - support the analysis of a design as it evolves;
 - simulate the behavior or performance of a design;
 - record the shape or geometry of a design;
 - communicate design ideas among designers;
 - ensure that a design is complete (as a drawing and its associated marginalia may remind us of still-undone parts of that design);
 - communicate the final design to the manufacturing specialists.

SKETCHING

- Sketching is a powerful tool in design because it enables us to convey our design ideas to others quickly and concisely.
- Types
 - A. Orthographic sketches
 - lay out the front, right and top views of a part
 - B. Axonometric sketches
 - start with an axis, typically a vertical line with two lines 30 degree from the horizontal.
 - C. Oblique sketches
 - The front view is blocked in roughly first, depth lines are then added, and details such as rounded edges are added last.
 - D. Perspective sketches

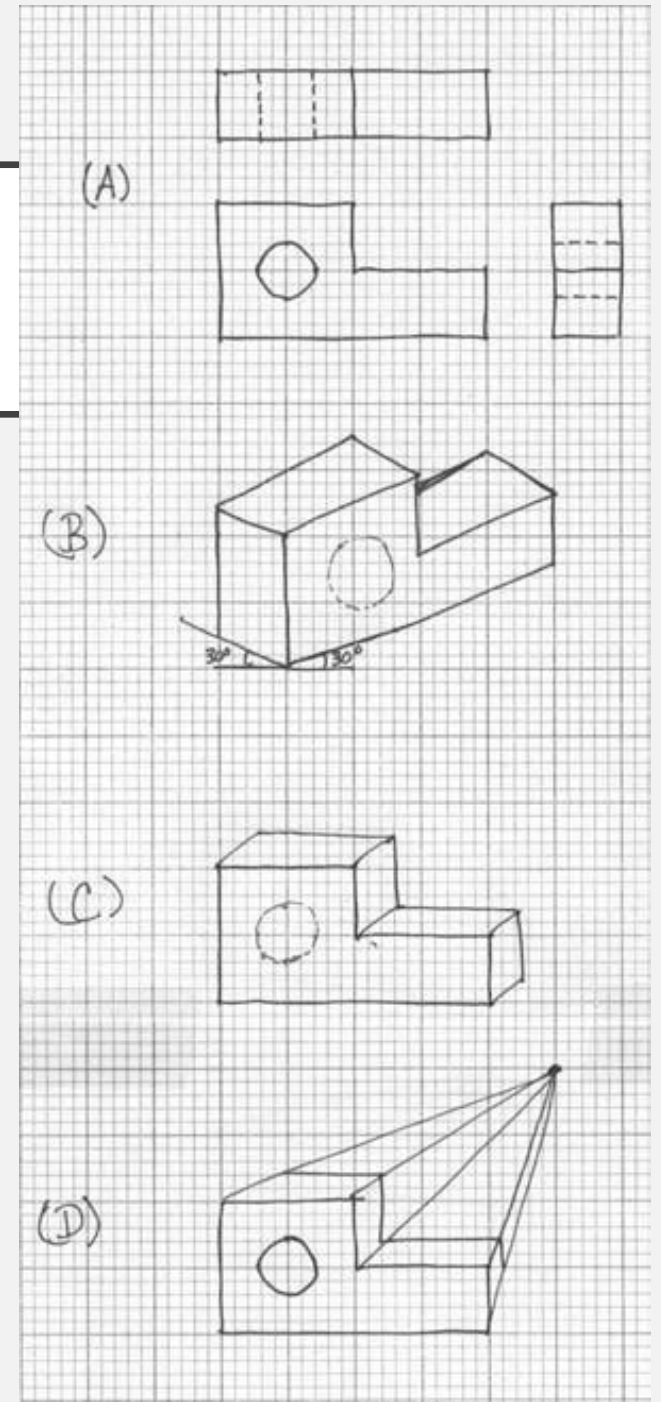



THE SEVERAL FORMS OF ENGINEERING DRAWINGS

- When we communicate design results to a manufacturer, we must think very carefully about the fabrication specifications that we are creating in drawings, as well as those we write.
- we must ensure that our drawings are both appropriate to our design and prepared in accordance with relevant engineering practices and standards.

DESIGN DRAWINGS

- Layout drawings
 - working drawings that show the major parts or components of a device and their relationship
 - They are usually drawn to scale, do not show tolerances, and are subject to change as the design process evolves.

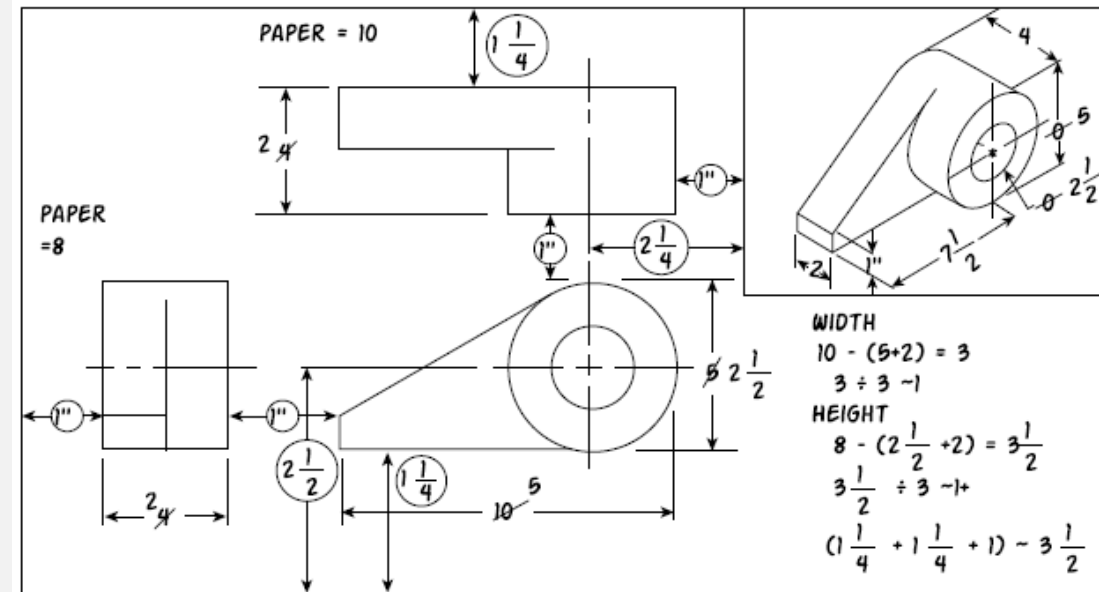



DESIGN DRAWINGS

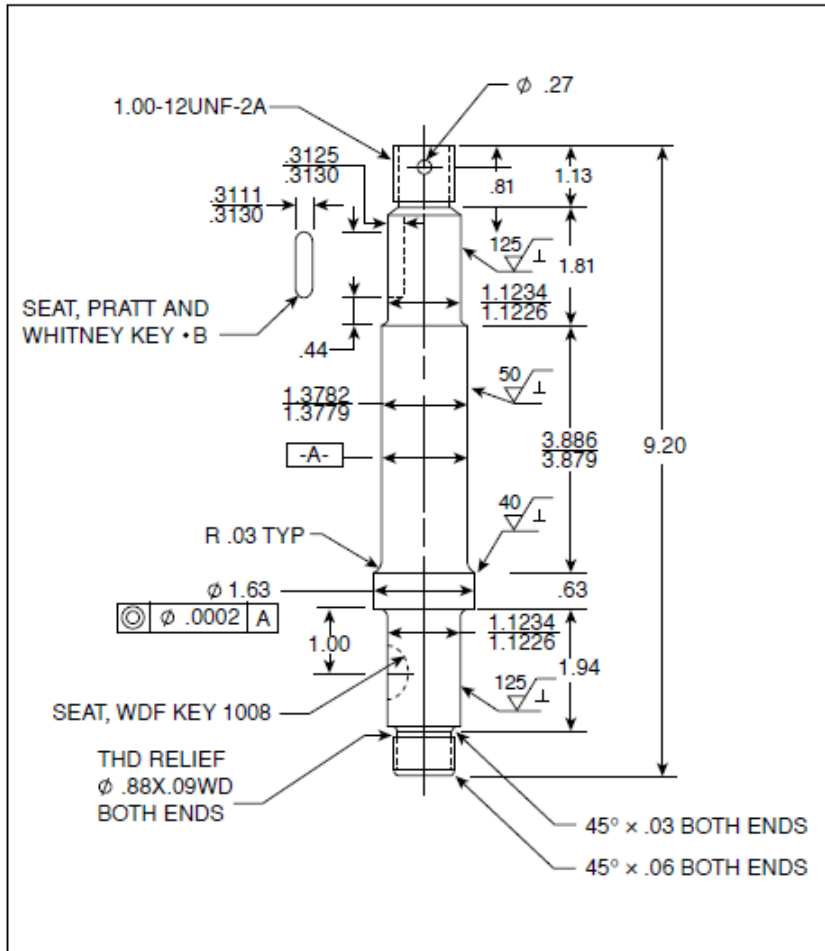

- Detail drawings
 - show the individual parts or components of a device and their relationship
 - These drawings must show tolerances, and they must also specify materials and any special processing requirements.
 - Detail drawings are drawn in conformance with existing standards, and are changed only when a formal change order provides authorization.

PRT.NO.	TITLE	SCALE	REVISION	CHANGE	DATE
2	SHAFT	FULL	W.J.K	E.T.B	F.D.M.
REQD.	LIMITS UNLESS OTHERWISE NOTED DECIMAL ± .010 ANGULAR ± 1/2°	DATE	GRAPHICOMP INC.		DWG. NO.
1		11-13-67	COLUMBUS, OHIO		1002



ASSEMBLY DRAWINGS

- Assembly drawings
 - show how the individual parts or components of a device fit together. An exploded view is commonly used to show such “fit” relationships

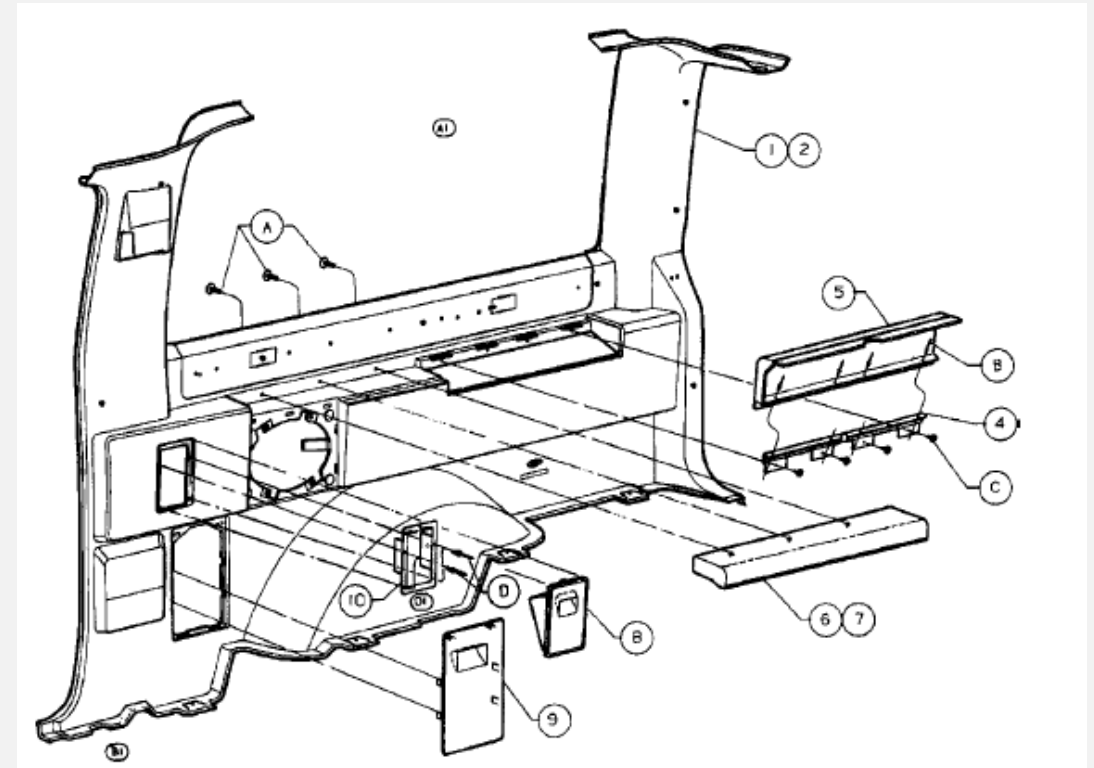



DETAIL DRAWINGS

- These drawings are used to communicate the details of our design to the manufacturer or machinist.
- They must contain as much information as possible while being both as clear and as uncluttered as possible.
- There are certain essential components that every drawing must have to ensure that it is interpreted as it is intended
 - standard drawing views;
 - standard symbols to indicate particular items;
 - clear lettering;
 - clear, steady lines;
 - appropriate notes, including specifications of materials;
 - a title on the drawing;
 - the designer's initials and the date it was drawn;
 - dimensions and units; and
 - permissible variations, or tolerances.

CAD - MODELS

- Good for digital visualization
- The making of 3D models in computers software is called geometric modelling
- Lots of CAD software are available depending on the application
- These software provide many features such as color rendering shading texting etc. to communicate the design more close to the reality
- The modelled part can be rotated, sectioned and zoomed so that any Complex shape can be communicated to the another person without confusion

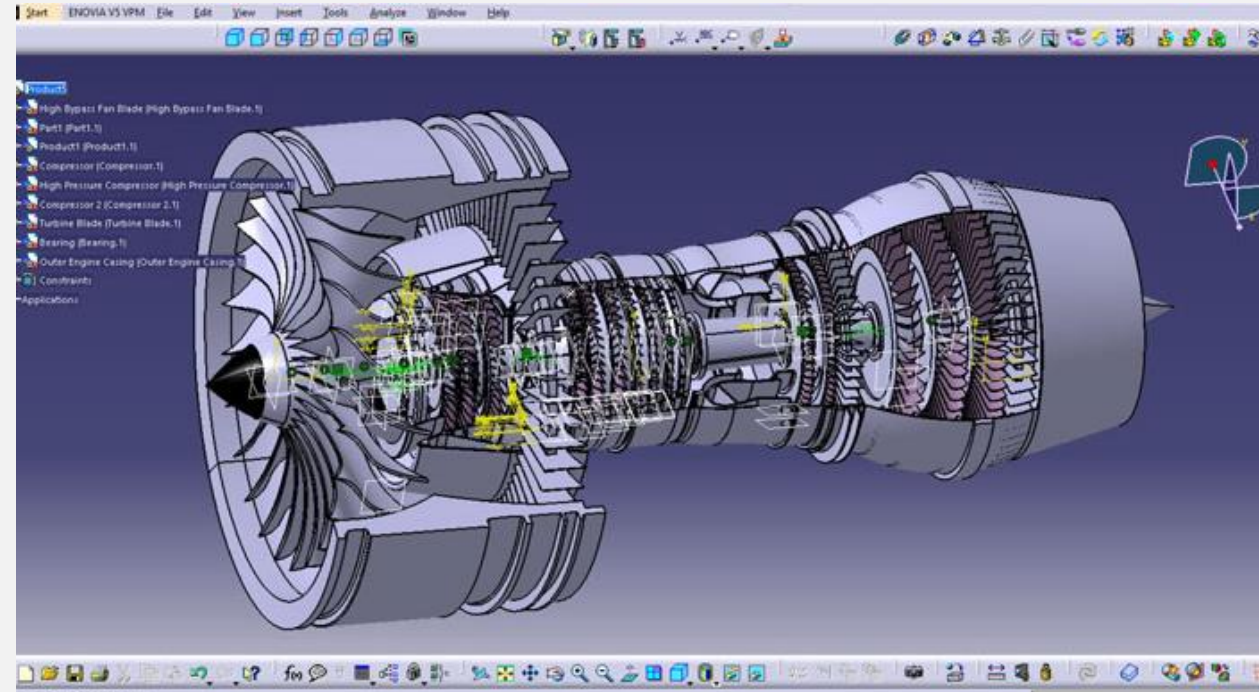

DETAIL DRAWINGS

Figure : A detail drawing of the handle of a screwdriver. This drawing uses a set of symbols and the particular placement of these symbols conveys information about the size and location of certain features of the screwdriver handle. In addition, the drawing contains information about the materials to be used, the finish of the part, the person who created it, and the date it was created. Drawing courtesy of R. Erik Spjut.

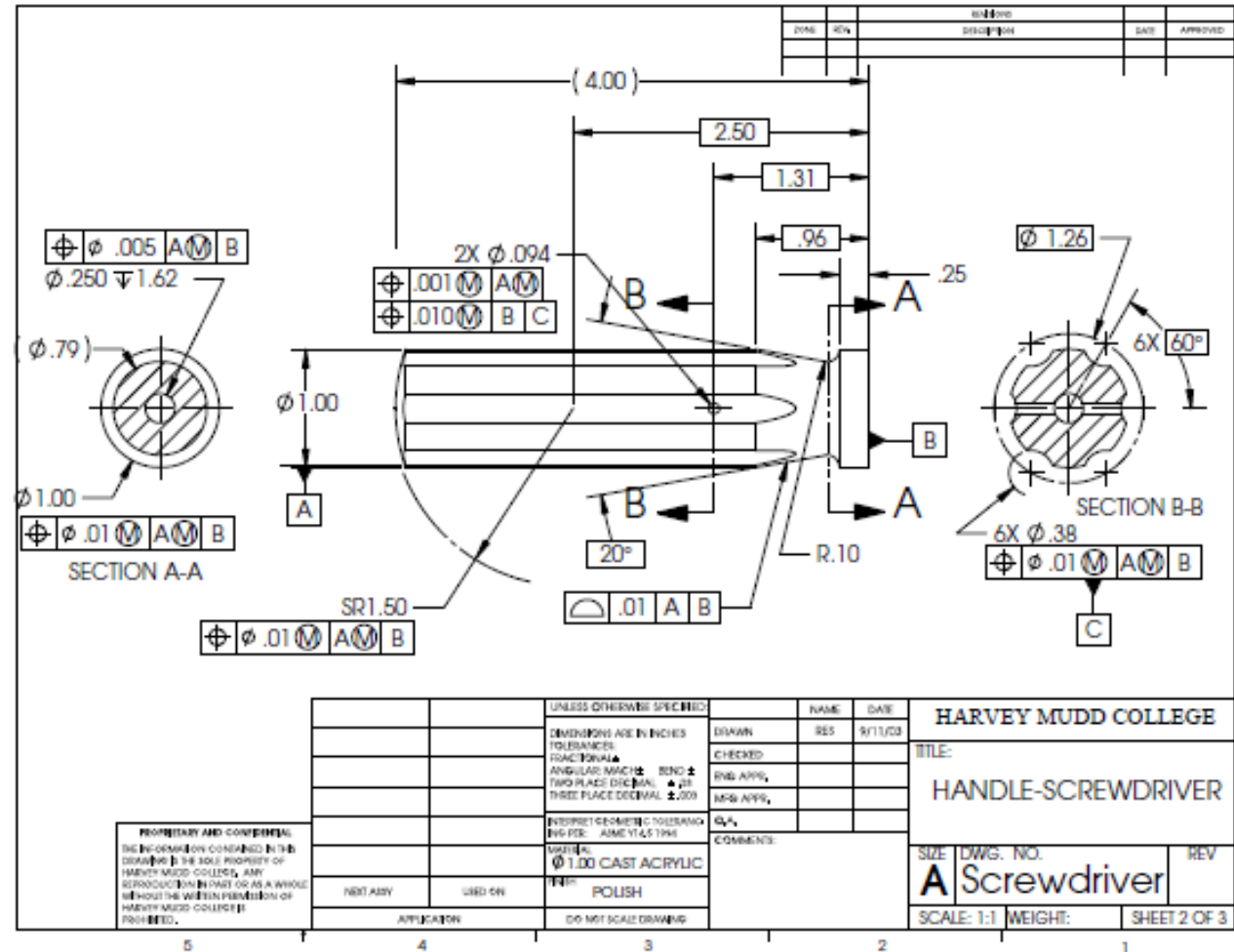



COMMUNICATING DESIGNS ORALLY AND IN WRITING

- REPORTING is an essential part of a design project
- We communicate final design results in several ways, including oral presentations, final reports (that may include design drawings and/or fabrication specifications), and prototypes and models.
- The primary purpose of such communication is to inform our client about the design, including explanations of how and why this design was chosen over competing design alternatives.
- It is most important that we convey the results of the design process.
- we should ensure that final reports and presentations are **not narratives** or chronologies of our work
- Rather, the presentations and reports should be lucid descriptions of **design outcomes**, as well as the processes with which those outcomes were **achieved**.



GUIDELINES FOR TECHNICAL COMMUNICATION

1. Know your purpose.
2. Know your audience.
3. Choose and organize the content around your purpose and your audience.
4. Write precisely and clearly.
5. Design your pages well.
6. Think visually.
7. Write ethically!





GUIDELINES FOR TECHNICAL COMMUNICATION

1. Know your purpose

- This is the writing analog of understanding objectives and functions for a designed artifact.
- Just as we want to understand what the designed object must be and must do, we need to understand the goals of a report or presentation.
- design documentation seeks to inform the client about the features of a selected design
- design team may be trying to persuade a client that a design is the best alternative.
- a designer may wish to report how a design operates to users, whether beginners or highly experienced ones.



GUIDELINES FOR TECHNICAL COMMUNICATION

2. Know your audience

- When documenting a design, it is essential that a design team structure its materials to its targeted audience.
- Taking time to understand the target audience will help ensure that its members appreciate your documentation



GUIDELINES FOR TECHNICAL COMMUNICATION

3. Choose and organize the content around your purpose and your audience

- The key element is to structure the presentation to best reach the audience
- There are many different ways to organize information
 - going from general concepts to specific details (analogous to deduction in logic),
 - going from specific details to general concepts (analogous to induction or inference),
 - describing devices or systems.
- Once an organizational pattern is chosen, no matter which form is used, the design team should translate it into a written outline. This allows the team to develop a unified, coherent document or presentation while avoiding needless repetition.





GUIDELINES FOR TECHNICAL COMMUNICATION

4. Write *precisely and clearly*

- Some specific elements that seem to occur in all good writing and presentations.
- These include effective use of short paragraphs that have a single common thesis or topic
- Direct sentences that contain a subject and a verb; and active voice and action verbs that allow a reader to understand directly what is being said or done.
- Opinions or viewpoints should be clearly identified as such.
- As long as the designer remembers that the goals of both technical and nontechnical communications remain the same.



GUIDELINES FOR TECHNICAL COMMUNICATION

5. Design your pages well

- A long section divided into several subsections helps readers to understand where the long section is going, and it sustains their interest over the journey.
- Tables should be treated as a single figure and should not be split over a page break.
- Simple and direct slides encourage readers to listen to the speaker without being distracted visually
- Thus, text on a slide should present succinct concepts that the presenter can amplify and describe in more detail. A slide does not have to show every relevant thought.
- It is a mistake to fill slides with so many words (or other content) that audiences have to choose between reading the slide and listening to the speaker, because then the presenter's message will almost certainly be diluted or lost.



GUIDELINES FOR TECHNICAL COMMUNICATION

6. Think visually

- Just as designers often find that visual approaches are helpful to them, audiences are helped by judicious use of visual representation of information.
- Given the enormous capabilities of word processing and presentation graphics software, there is no excuse for a team not to use visual aids in its reports and presentations.
- A team should not allow their graphics' capabilities to seduce them into clouding their slides with artistic backgrounds that make the words illegible.
- As it is with words, is to know your purpose and your audience, and to use your medium appropriately.





GUIDELINES FOR TECHNICAL COMMUNICATION

7. Write ethically!

- All results or test outcomes, even those that are not favorable, are presented and discussed.
- Ethical presentations also describe honestly and directly any limitations of a design.
- It is also important to give full credit to others, such as authors or previous researchers, where it is due



ORAL PRESENTATIONS

- TELLING A CROWDWHAT'S BEEN DONE
 - Most design projects call for a number of both formal and informal presentations to clients, users, and technical reviewers
 - Because of the variety of presentations and briefings that a team may be called upon to make, it is impossible to examine each of them in detail.
 - However, there are key elements common to most of them.
 - Foremost among these needs to
 1. Identify the audience
 2. Outline the presentation
 3. Develop appropriate supporting materials
 4. Practice the presentation



KNOWING THE AUDIENCE

- Who's Listening?
- a team planning a briefing should consider factors such as varying levels of interest, understanding, and technical skill, as well as the available time.
- Once the audience has been identified, a team can tailor its presentation to that audience.
- As with other deliverables, the presentation must be properly organized and structured:
 - The first step is to articulate a rough outline;
 - The second is to formulate a detailed outline;
 - The third is to prepare the proper supporting materials, such as visual aids or physical models.





THE PRESENTATION: OUTLINE

- **A title slide** : that identifies the client(s), the project, and the design team or organization responsible for the work being presented. This slide should include company logos.
- **A roadmap** : for the presentation that shows the audience the direction that the presentation will take. This can take the form of an outline, a flowchart, a big picture slide, and so on.
- **A problem statement**: which includes highlights of the revised problem statement that the team produced after research and consultation with the client.
- **Background material on the problem**: including relevant prior work and other materials developed through team research. References should be included but may be placed in a slide at the end of the presentation.
- **The key objectives of the client and users** : as reflected in the top level or two of the objectives tree.
- **The key constraints** that the design must meet.
- **Functions that the design must perform** : focusing on basic functions, and means for achieving those functions.



THE PRESENTATION: OUTLINE

- **Design alternatives** : particularly those that were considered at the evaluation stage, including diagrams and descriptions of each.
- **Highlights of the evaluation procedure and outcomes**: including key metrics or objectives that bear heavily on the outcome.
- **The selected design** : explaining why this design was chosen.
- **Features of the design** : highlighting aspects that make it superior to other alternatives and any novel or unique features.
- **Proof-of-concept testing** : especially for an audience of technical professionals for whom this is likely to be of great interest.
- **A demonstration of the prototype** : assuming that a prototype was developed and that it can be shown. Video or still photos may also be appropriate here.
- **Conclusion(s)**: including the identification of any future work that remains to be done, or suggested improvements to the design.



PRESENTATIONS ARE VISUAL EVENTS

- At the earliest stages of the presentation planning, the design team should find out what devices (e.g., overhead projectors, computer connections, projectors, and whiteboards) are available and the general setting of the room in which it will be presenting.
- Tips & pointers
 - Limit the number of slides.
 - Be sure to introduce yourself and your teammates on the title slide.
 - Beware of “clutter.” Slides should be used to highlight key points; they are not a direct substitute for the reasoning of the final report.
 - Make points clearly, directly, and simply
 - Use color skillfully
 - Use animation appropriately
 - Do not reproduce completed design tools
 - Consider carefully the size and distance of the audience



PRACTICE MAKES PERFECT

- To be effective, speakers typically need to practice their parts in a presentation alone, then in front of others, including before an audience with at least some people who are not familiar with the topic.
- we want to speak to an audience in their language, and that we want to maintain a professional tone.
- Practice sessions, whether solitary or with others, should be timed and done under conditions that come as close as possible to the actual environment.
- While practicing its presentation, a team ought to prepare for questions from its audience by:
 - Generating a list of questions that might arise, and their answers;
 - Preparing supporting materials for points that are likely to arise (e.g., backup slides that may include computer results, statistical charts, and other data that may be needed to answer anticipated questions)
 - Preparing to say “I don’t know,” or “We didn’t consider that.” This is very important: A team, that is, to be caught pretending to know has undermined its credibility and invited severe embarrassment.



MATHEMATICAL MODELING IN DESIGN

- MATHEMATICAL MODELS are central to design because we have to be able to predict the behavior of the devices or systems that we are designing.
- It is important for us to ask: How do we create mathematical models? How do we validate such models? How do we use them? And, are there any limits on their use?



SOME MATHEMATICAL HABITS OF THOUGHT FOR DESIGN MODELING

- We will focus on representing the behavior and function of real devices in mathematical terms.
- Basic Principles of Mathematical Modeling
 - Why do we need a model?
 - For what will we use the model?
 - What do we want to find with this model?
 - What data are we given?
 - What can we assume?
 - How should we develop this model, that is, what are the appropriate physical principles we need to apply?
 - What will our model predict?
 - Can we verify the model's predictions (i.e., are our calculations correct?)
 - Are the predictions valid (i.e., do our predictions conform to what we observe?)
 - Can we improve the model?



ABSTRACTIONS, SCALING, AND LUMPED ELEMENTS

- **Abstractions** : An important decision in modeling is choosing the right level of detail for the problem, which thus dictates the level of detail for the model.
- Stated differently, thinking about finding the right level of abstraction or detail means identifying the right **scale** for our model means thinking about the magnitude or size of quantities measured with respect to a standard that has the same physical dimensions.
- we often say that a “real,” three-dimensional object behaves like a simple spring. When we say this, we are introducing the idea of a **lumped element** model in which the actual physical properties of a real object or device are aggregated or lumped into less detailed, more abstract expressions.



SOME MATHEMATICAL TOOLS FOR DESIGN MODELING

- **Dimensions and Units**
 - Every independent term in every equation we use has to be dimensionally homogeneous or dimensionally consistent, that is, every term has to have the same net physical dimensions.
 - The physical quantities used to model objects or systems represent concepts, such as time, length, and mass, to which we attach numerical measurements or values.
 - **Fundamental or primary quantities** can be measured on a scale that is independent of those chosen for any other fundamental quantities. For example, mass, length, and time are usually taken as the fundamental mechanical dimensions or variables.
 - **Derived quantities** generally follow from definitions or physical laws, eg : force is a derived quantity that is defined by Newton's law of motion.



DIMENSIONS AND UNITS

- If mass, length, and time are chosen as primary quantities, then the dimensions of force are (mass x length)/(time)². We use the notation of brackets [] to read as “the dimensions of.” If M, L, and T stand for mass, length, and time, respectively, then

$$[F = \text{force}] = (M \times L)/(T)^2$$

- Similarly, [A=area]=(L)² and [ρ = density] = M/(L)³.
- The units of a quantity are the numerical aspects of a quantity's dimensions expressed in terms of a given physical standard



SOME MATHEMATICAL TOOLS FOR DESIGN MODELING

• Significant Figures

- In scientific notation, the number of significant figures is equal to the number of digits counted from the first nonzero digit on the left to either
 - (a) The last nonzero digit on the right if there is no decimal point, or
 - (b) The last digit (zero or nonzero) on the right when there is a decimal point.
- we should always remember that the results of any calculation or measurement cannot be any more accurate than the least accurate starting value.
- any calculation is only as accurate as the least accurate value we started with

TABLE 12.1 Numbers written in different forms, together with the *number of significant figures (NSF)* of each and an assessment of the NSF that can be assumed or inferred. Confusion about the NSF arises because of the meaning of the terminal zeroes is not stated

Measurement	Significant Figures	Assessment
5415	Four	Clear
5400	Two (54×10^2) or three (540×10^1) or four (5400)	Not clear
54.0	Three	Clear
54.1	Three	Clear
5.41	Three	Clear
0.00541	Three	Clear
5.41×10^3	Three	Clear
0.054	Two	Clear
0.0540	Two (0.054) or three (0.0540)	Not clear
0.05	One	Clear



SOME MATHEMATICAL TOOLS FOR DESIGN MODELING

- **Dimensional Analysis**
 - We can learn a lot about some behavior by doing dimensional analysis, that is, by expressing that behavior in a dimensionally correct equation among certain variables or dimensional groups.
 - The basic method of dimensional analysis is an informal unstructured approach for determining dimensional groupings that depends on constructing a functional equation that contains all of the relevant variables, for which we know the dimensions
 - We then identify the proper dimensionless groups by thoughtfully eliminating dimensions.



SOME MATHEMATICAL TOOLS FOR DESIGN MODELING

- **Physical Idealizations, Mathematical Approximations, and Linearity**
 - First, we identify those elements that we believe are important to the problem.
 - Second, we translate our physical idealization into a mathematical model
 - Third, try to build models that are, mathematically speaking, linear models. Linearity shows up in other contexts. Consider geometrically similar objects, that is, objects whose basic geometry is essentially the same.



CONSERVATION AND BALANCE LAWS

- Many of the mathematical models used in engineering design are statements that some property of an object or system is being conserved.
- Such balance or conservation principles are applied to assess the effect of maintaining levels of physical attributes.
- Conservation and balance equations are related: Conservation laws are special cases of balance laws.



PROTOTYPING AND PROOFING THE DESIGN

- Focus on how to translate our design ideas into models and prototypes that can be used to test our design concepts and communicate our ideas to the client.
- Often the first step in such a process involves sketching or drawing our design, we can use these representations to create the prototype or model.
- 3D representation
 - as an input to a computational modeling program to simulate the design's performance under specified conditions;
 - as an input into a variety of rapid prototyping technologies, such as 3D printing;
 - to generate detailed engineering drawings of the design;
 - to guide
 - the tool path in computer numerical-controlled (CNC) machining



PROTOTYPES

- “original models on which something is patterned.” They are also defined as the “first full-scale and usually functional forms of a new type or design of a construction
- prototypes are working models of designed artifacts.
- They are tested in the same operating environments in which they’re expected to function as final products.



MODEL

- “a miniature representation of something,” or a “pattern of something to be made,” or “an example for imitation or emulation.”
- We use models to represent some devices or processes.
- They may be paper models or computer models or physical models.
- We use them to illustrate certain behaviors or phenomena as we try to verify the validity of an underlying (predictive) theory.
- Models are usually smaller and made of different materials than are the original artifacts they represent, and they are typically tested in a laboratory or in some other controlled environment to validate their expected behavior.



PROOF OF CONCEPT

- refers to a model of some part of a design that is used specifically to test whether a particular concept will actually work as proposed.
- Doing proof-of-concept tests means doing controlled experiments to prove or disprove a concept.



WHEN DO WE BUILD A PROTOTYPE?

- “It depends.”
- the size and type of the design space,
- the costs of building a prototype,
- the ease of building that prototype,
- the role that a full-size prototype might play in ensuring the widespread acceptance of a new design,
- the number of copies of the final artifact that are expected to be made or built.
- There is no obvious correlation between the size and cost of prototyping—or the decision to build a prototype—and the size and type of the design space.
- it is that the project schedule and budget should reflect plans for building them.





BUILDING MODELS AND PROTOTYPES

- The important questions we must ask are:
 - What do we want to learn from the model or prototype?
 - Who is going to make it?
 - What parts or components can be bought?
 - How, and from what, is it going to be made?
 - How much will it cost?

BUILDING MODELS AND PROTOTYPES

- There are many options for constructing prototypes and models
 - **Mock-ups:** One option for making basic models or prototypes is to construct a mockup of a 3D part from 2D cutouts. These 2D parts can be made using a vinyl cutter or a laser cutter, and parts are then assembled into 3D mock-ups of a design. Materials used for these mock-ups might be foam, thin plastic, or wood.
 - **Machining:** We may have the option of machining parts or all of our prototypes ourselves in a machine shop.
 - **Rapid prototyping technologies:** Rapid prototyping technologies have emerged in recent years as relatively fast and cheap ways to fabricate prototypes that would otherwise need to be injection molded. Rapid prototyping techniques use 3D CAD models as inputs, and convert these 3D files into thin 2D layers to build the 3D part. Rapid prototyping technologies include stereo-lithography and selective laser sintering, which involve using a laser to harden either a resin bath or a polymer powder in a particular configuration to build each layer.

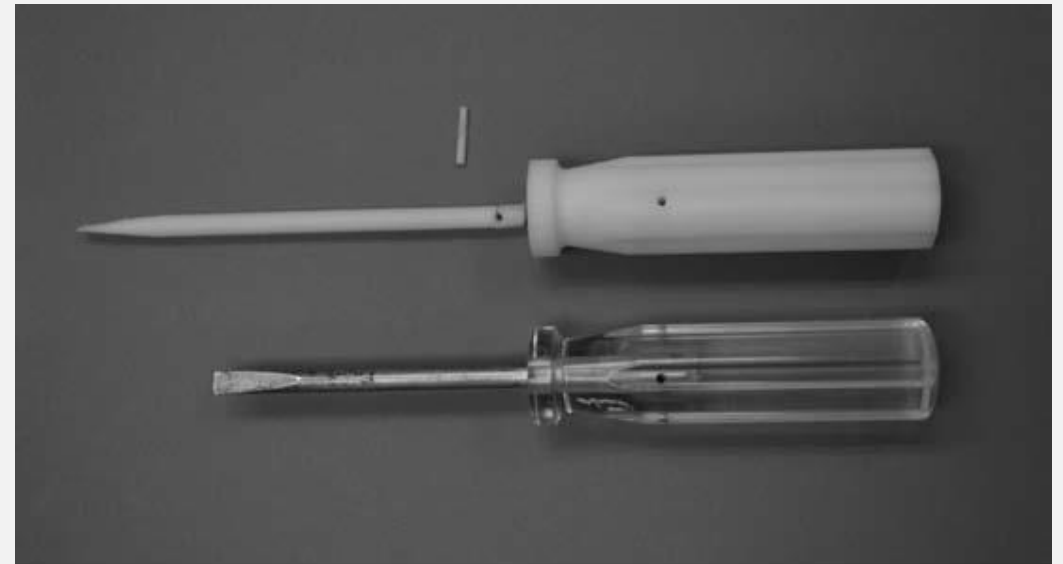



REFERENCES

- “ENGINEERING DESIGN:A PROJECT-BASED INTRODUCTION,” By CLIVE L. DYM, PATRICK LITTLE, and ELIZABETH J. ORWIN, fourth edition, wiley
- DESIGN & ENGINEERING : Basics of product development By Dr. SADIQ A

